

# 1. ΠΑΡΟΥΣΙΑΣΤΕΙΤΕ:



# 2.

Ξανασκεφτείτε το 'αυτονόητο' πρόγραμμα που συνδέεται με τα καθημερινά αντικείμενα

# 3. ΕΞΑΡΤΗΘΕΙΤΕ ΑΠΟ ΤΟΥΣ 'ΑΛΛΟΥΣ':



# 4.

επαναπροσδιορίστε το 'αντικείμενο' και τη στάση σας μέσα από την γειννίαση | σύνδεση | αλληλεπίδραση

# 5. ΣΧΕΔΙΑΣΤΕ ΣΥΛΛΟΓΙΚΑ

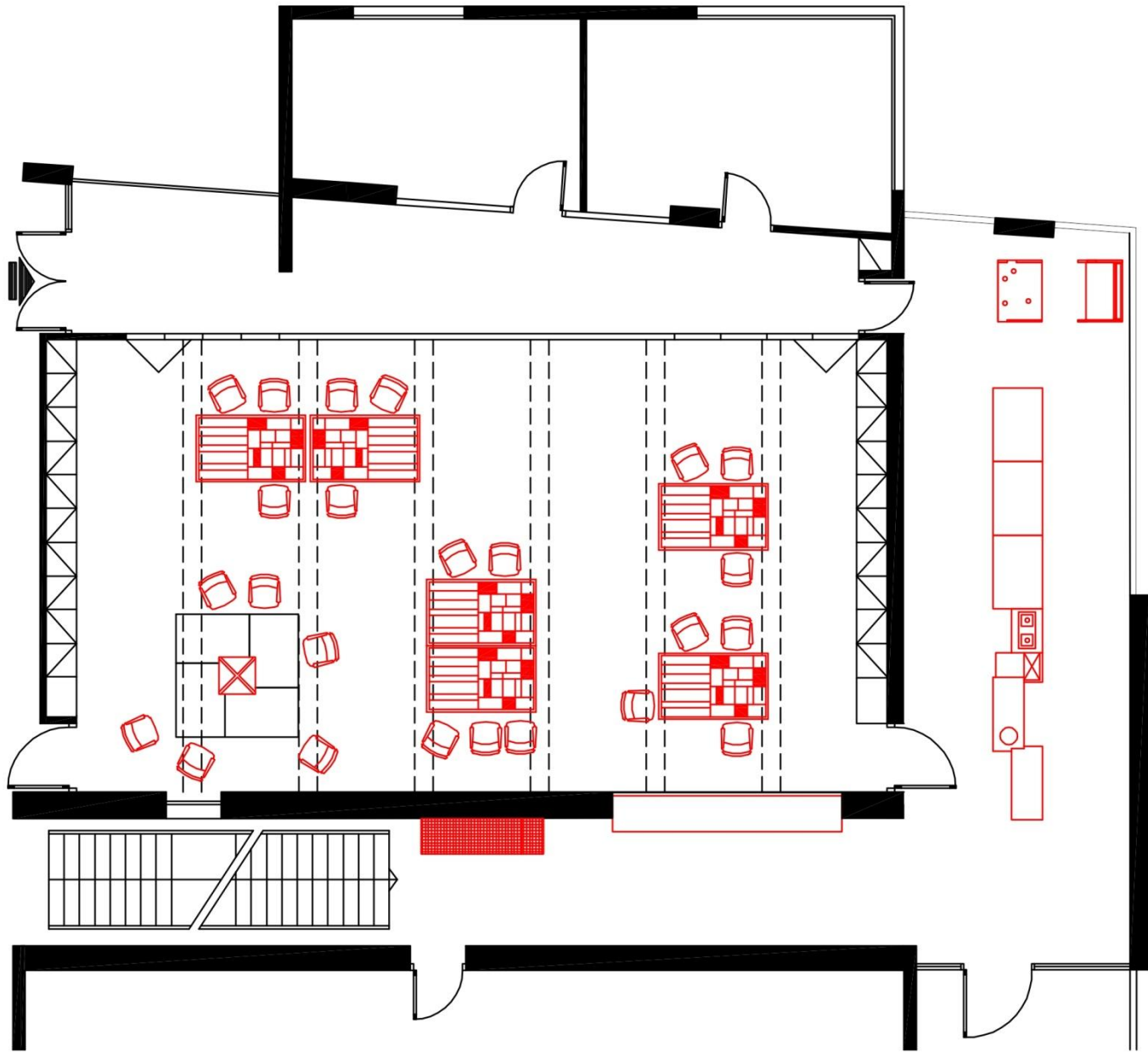

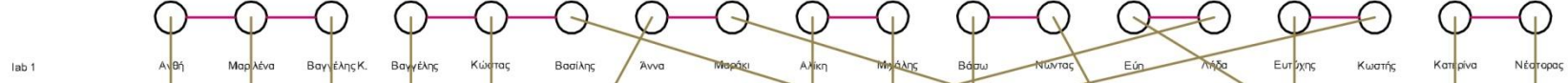
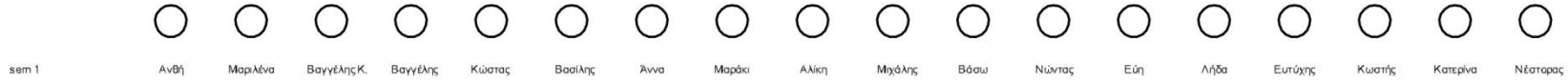
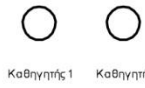
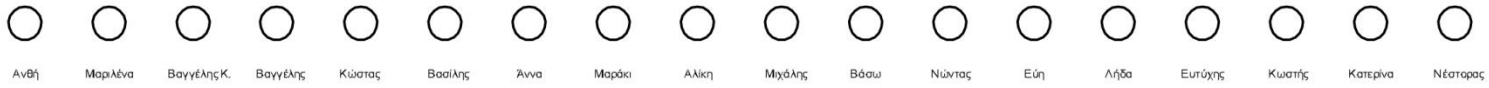

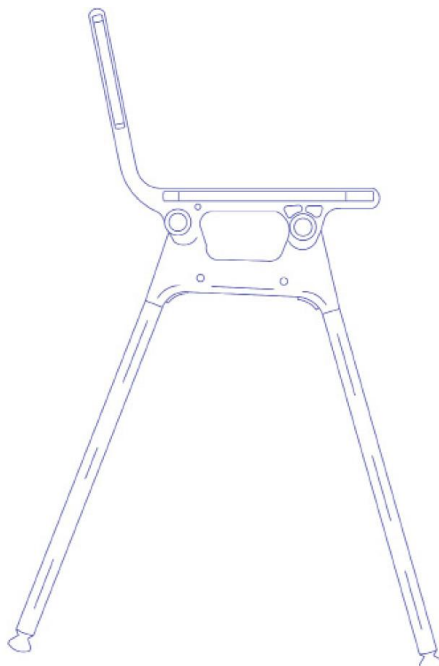

Εύρημα 1

70 εκ. \* 45 εκ.

Μεταλλικό

Δεν κόβεται / Δεν λυγίζει / Δεν τρυπιέται



detail\_01



detail\_02



detail\_03



detail\_04

















100% FUN

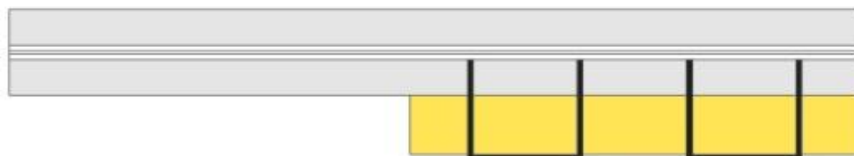

ΡΑΦΙΑ  
ΜΠΑΡΑ



33.3% FUN  
66.6% COOKING

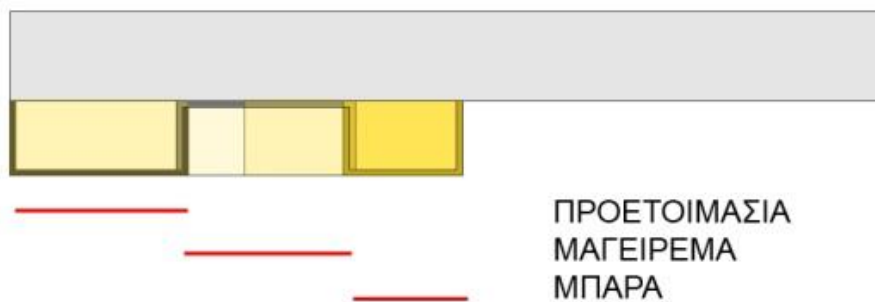

100% COOKING



ΑΠΟΘΗΚΕΥΣΗ  
ΠΡΟΕΤΟΙΜΑΣΙΑ  
ΜΑΓΕΙΡΕΜΑ  
ΣΕΡΒΙΡΙΣΜΑ

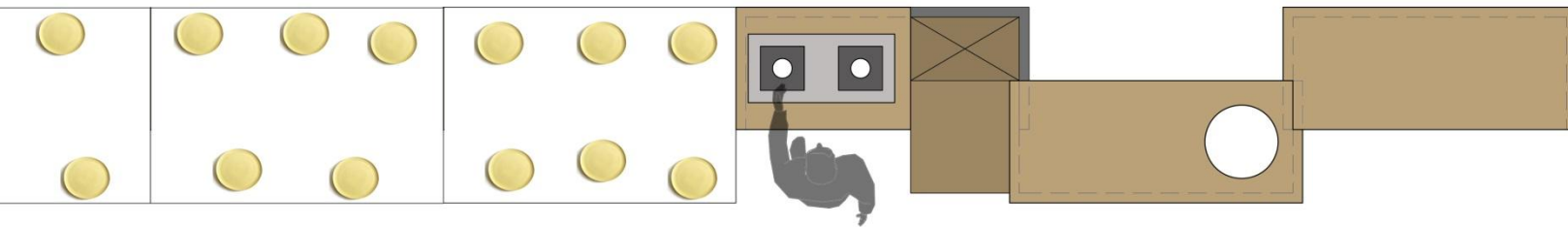

ΑΠΟΘΗΚΕΥΣΗ  
ΠΡΟΕΤΟΙΜΑΣΙΑ  
ΜΑΓΕΙΡΕΜΑ  
ΣΕΡΒΙΡΙΣΜΑ

plug-in<sub>table</sub>



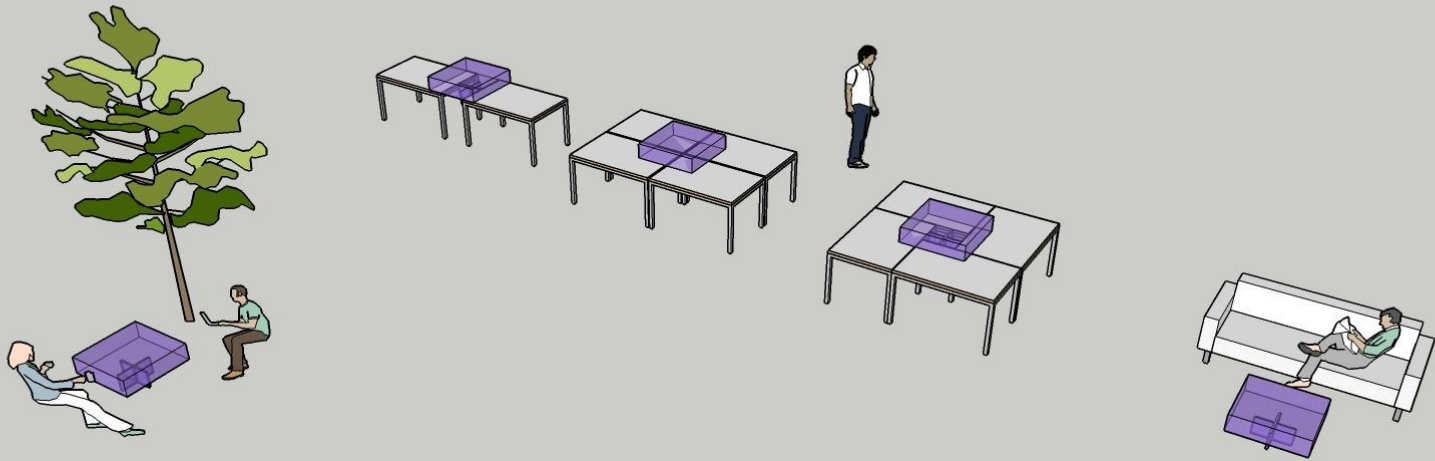

plug-in<sub>table</sub>

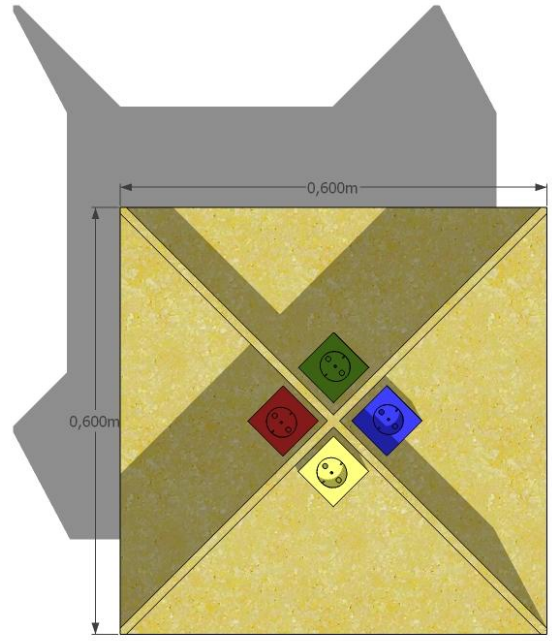

plug-in<sub>table</sub>



plug-in<sub>table</sub>

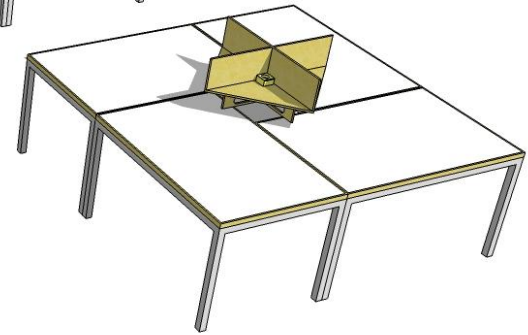
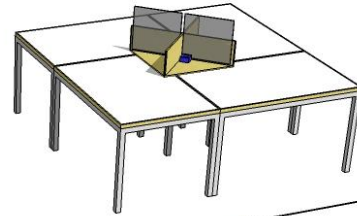
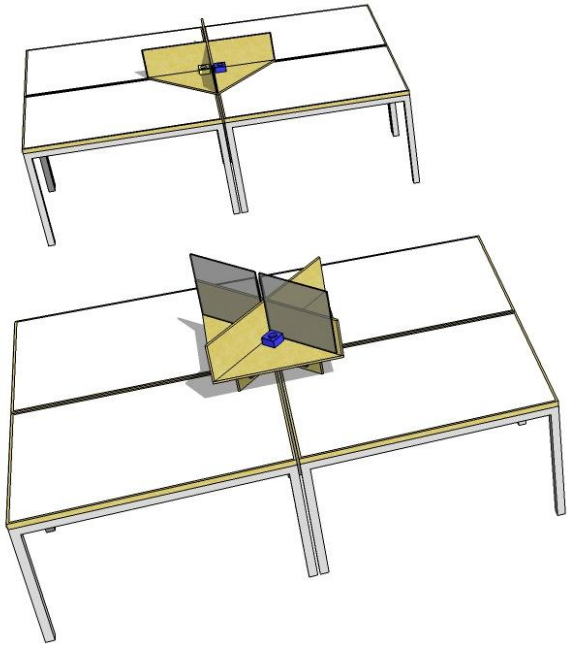

plug-in table



Με τη βοήθεια του Νέστορα, περνάμε τα ροδάκια

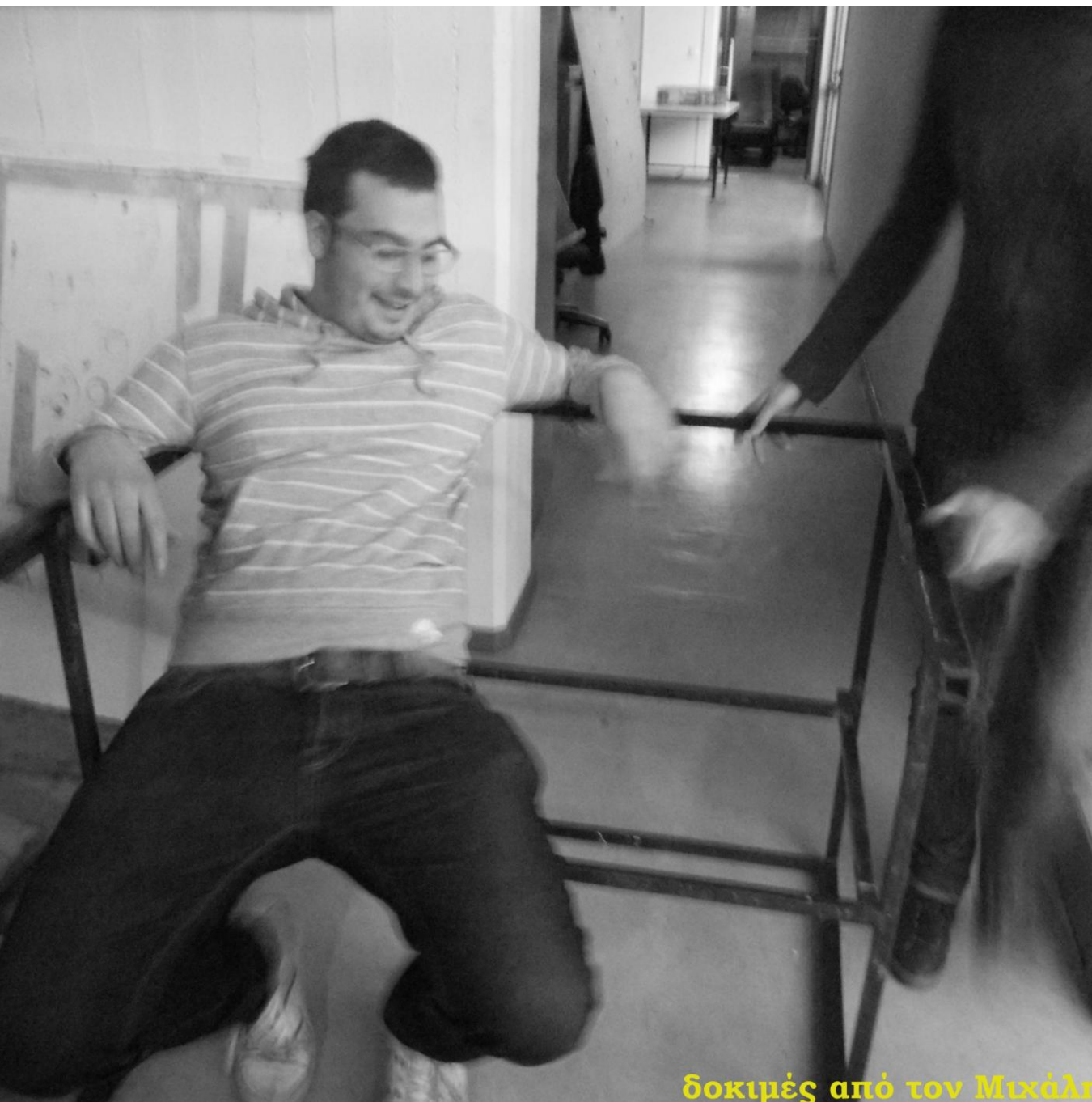

δοκιμές από τον Μιχάλη πριν κατασκευαστεί



επεξεργασία









\_Σχεδιασμός τραπεζιού εργασίας

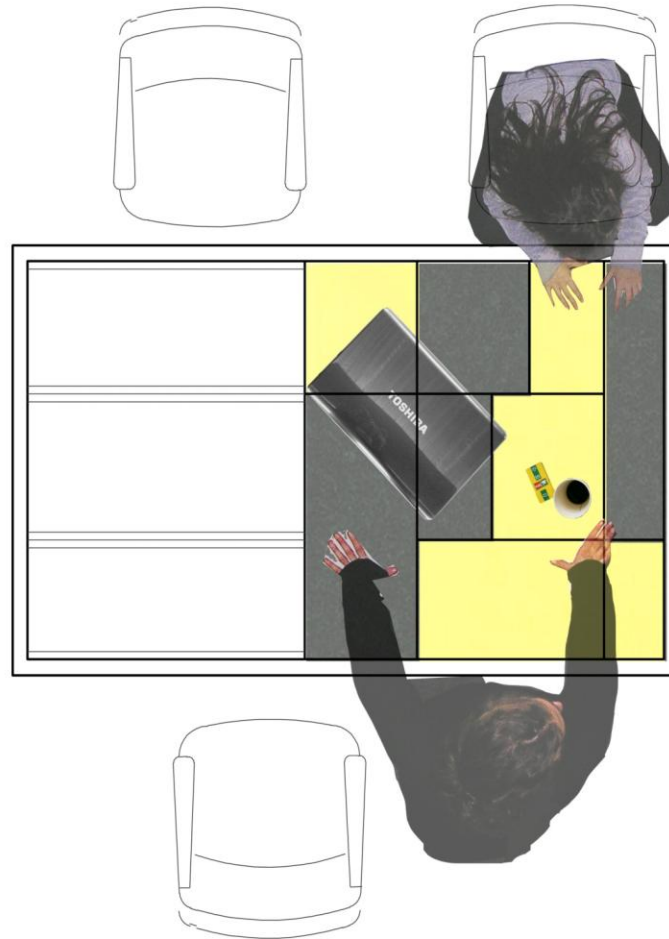

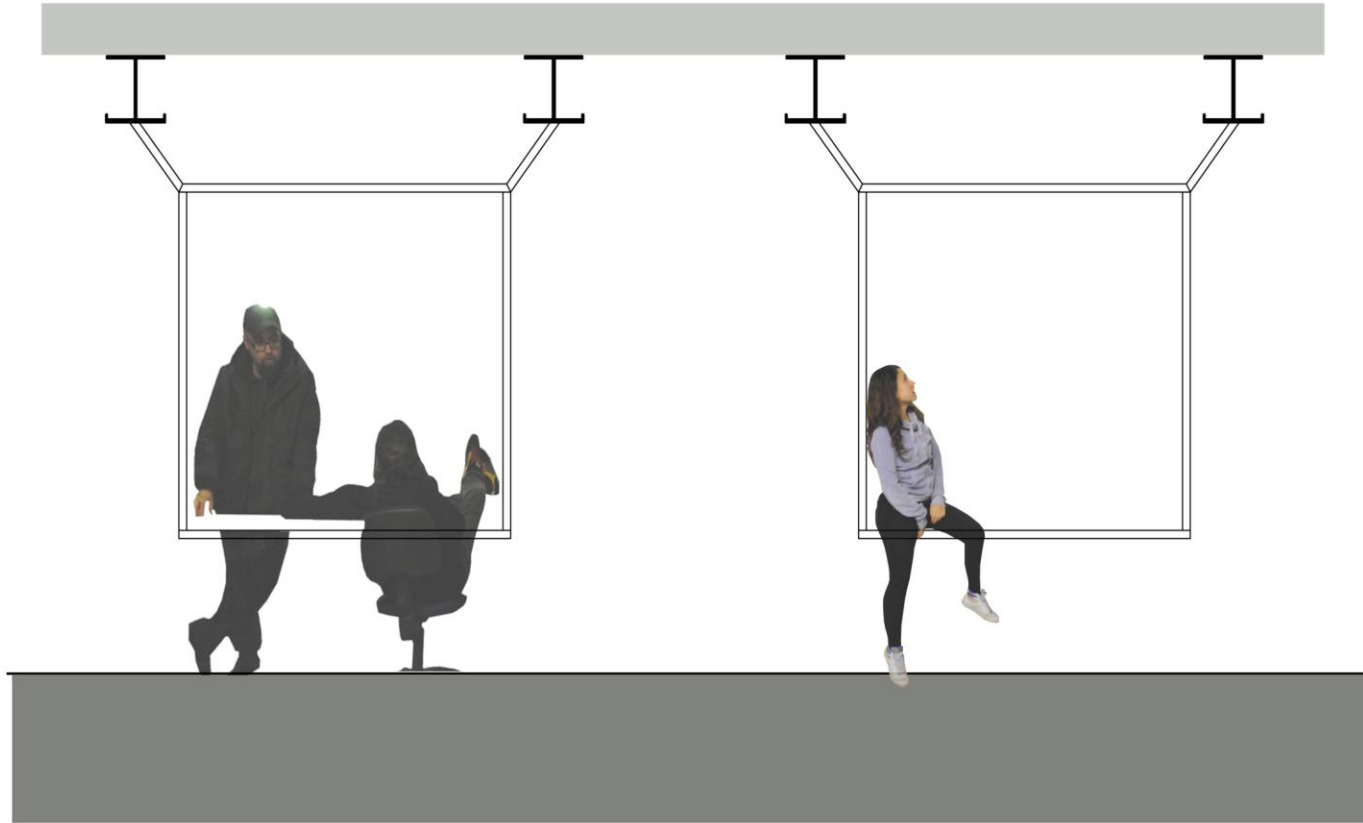

# \_Κατασκευή

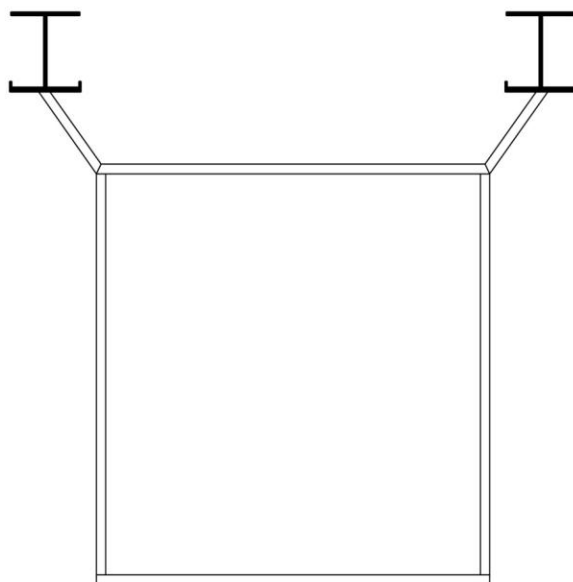
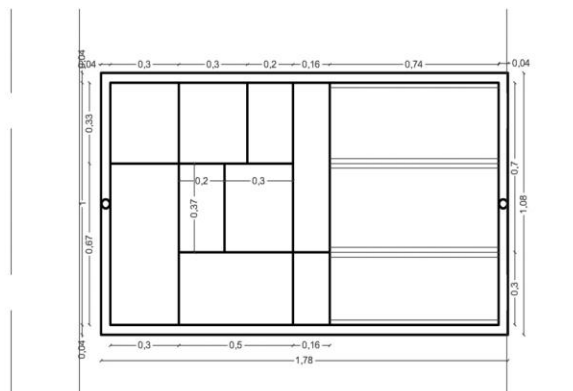

1.72

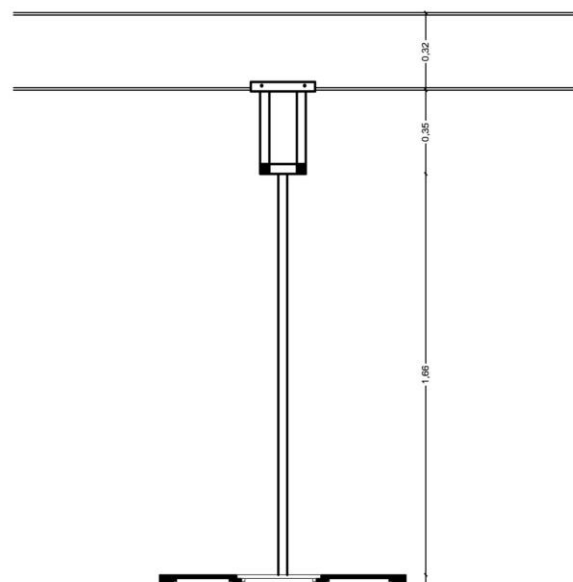
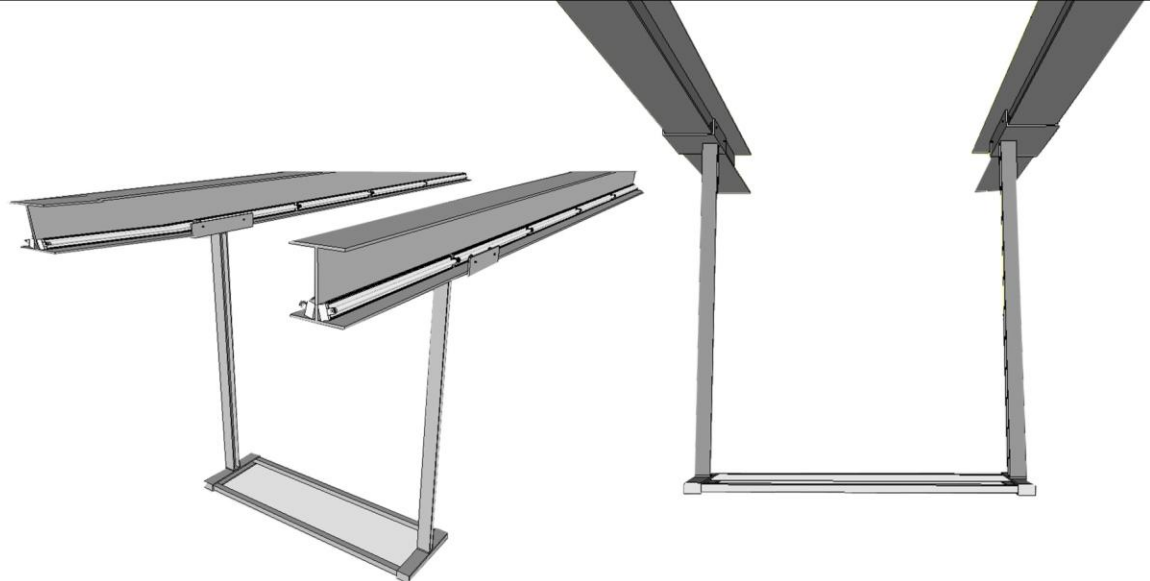

1.08

